

JUNQUAN[®]
JUNQUAN AUTOMATION
—— 君权自动化 ——

产品说明书

Product Specifications



PF-3
自动送线器

浙江君权自动化设备有限公司
ZHEJIANG JUNQUAN AUTOMATION CO.,LTD

Preface

When using this machine, please do read this book carefully. This machine will be premature damage and degradation of performance caused by wrong operation and usage. So please pay more attentions on below:

- 1、 Please check the supply voltage of this machine before using.
- 2、 Please be familiar with the instruction before running the machine.
- 3、 Please don not run the motor on braking state.
- 4、 PF-3 series wire feeder is devided into: single wire feeder (include fine wire, thick wire) and parallel wire feeder.
- 5、 Technical parameter

Device name	PF-3 series wire feeder
Wire shape	Coil wire
Shaft diameter	20mm
Coil size	Outer diameter 360mm, inner diameter 84-215mm
Power Supply	Single phase 220V \pm 10%50HZ, maximum current 92W
Control	Four stage speed regulation
Motor reduction ratio	1: 5
Speed	292/min, feeding 45mm
Weight	55Kg

Catalogue

Preface

Catalogue

1. PF-3(parallel wire)feeder exterior structure

1、 The front view of the machine

2、 Component details of front view

3、 The back view of the machine

4、 Component details of back view

2. PF-3(single wire)feeder exterior structure

1、 The front view of the machine

2、 Component details of front view

3、 The back view of the machine

5、 Component details of back view

3. Operating instruction

4. Wiring diagram

5. frequency converter setting

1. PF-3(parallel wire) feeder exterior structure

1. The front view of the machine

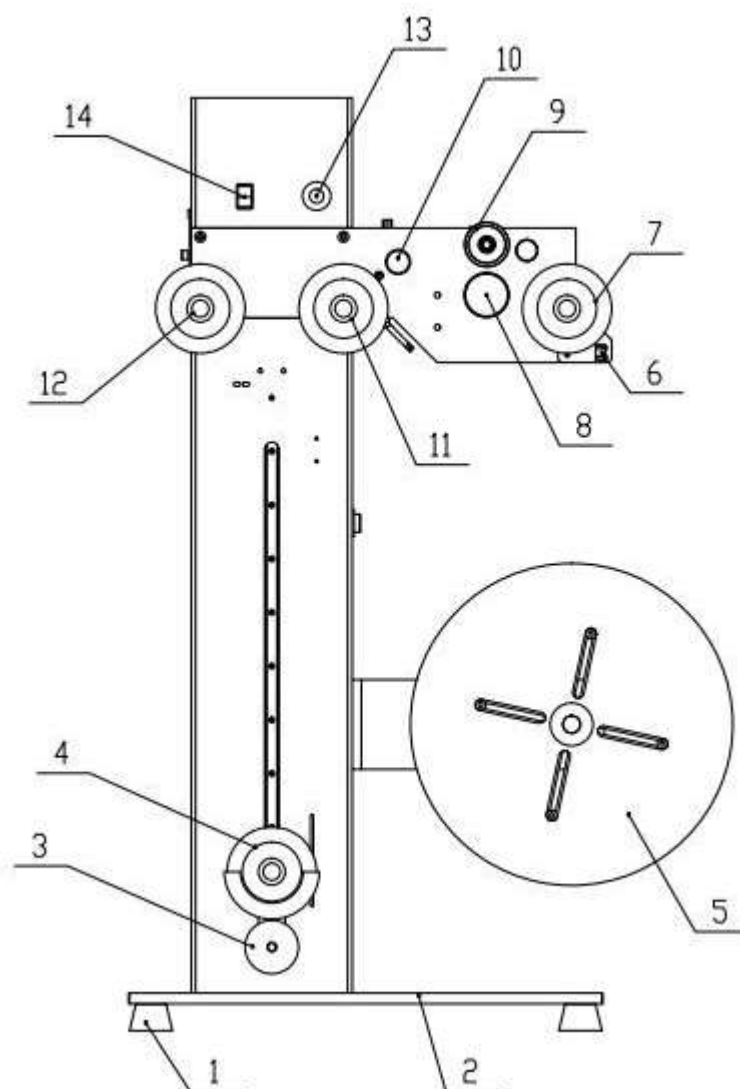

Pic.1 The front view of the machine

2. Component details of front view

1	Foot	2	Base	3	Distribution block
4	Lower roller for feed the wire	5	Plate for feed the roller	6	Nozzle

7	Upper roller for feed the wire	8	Subjective wire feed roller	9	objective wire feed roller
10	The button for adjust pressure the	11	Upper roller for feed the wire 1	12	Upper roller for feed the wire 2
13	Emergency stop switch	14	Main switch		

3. The back view of the machine

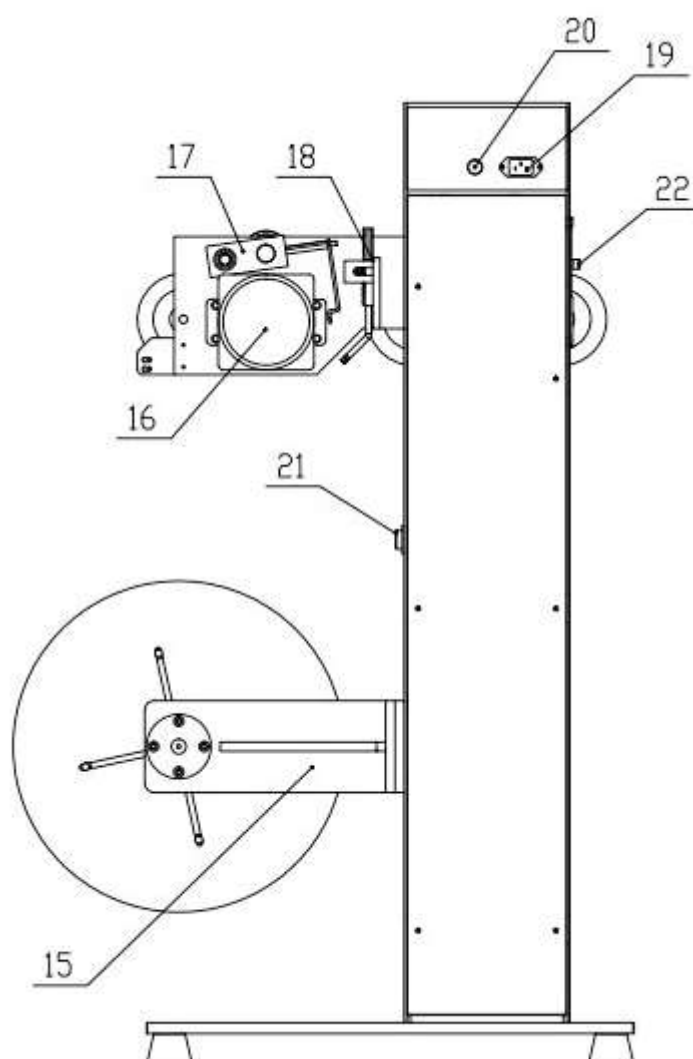

Pic. The back view of the machine

4. Component details of back view

15	Support board of wire feed plate	16	Motor	17	The Swing arm for feed the wire
----	----------------------------------	----	-------	----	---------------------------------

18	The Device for adjust the pressure	19	AC220V 3 phase power plugs	20	Base for keeping the safety tube
21	The Plug connects to the motor	22	Frequency controller		

2.PF-3(single wire)feeder exterior structure

1.The front view of the machine

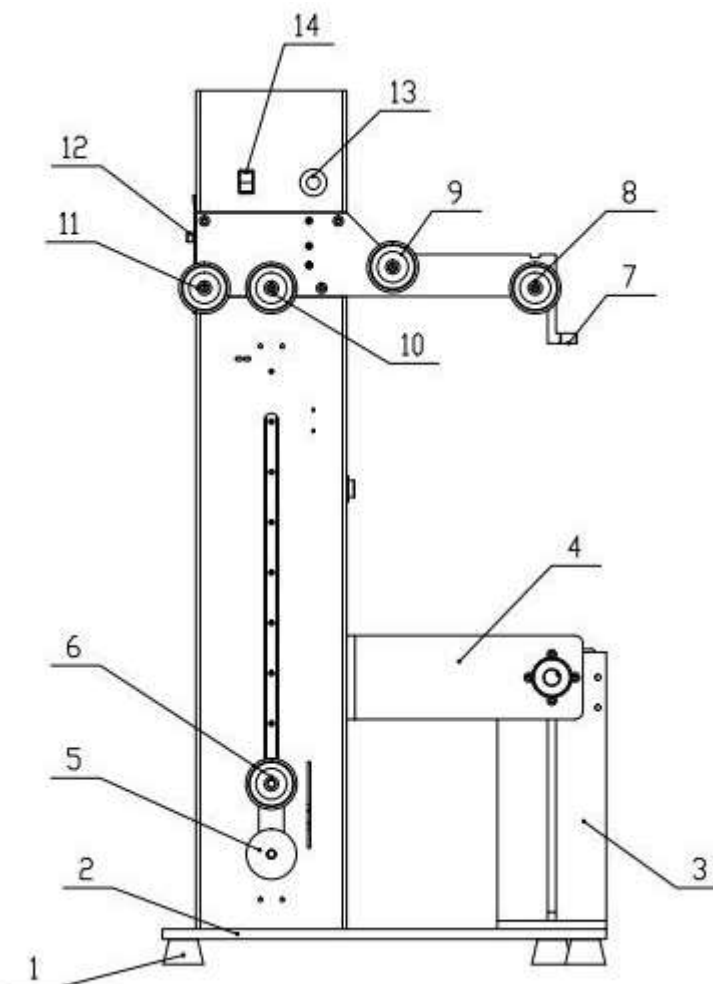

Pic.3 The front view of the machine

2. Component details of front view

1	Foot	2	Base	3	Motor Support
4	Support board of wire feed plate	5	Distribution block	6	Lower roller for feed the wire 1
7	Nozzle subassembly	8	Upper roller for feed the wire 1	9	Upper roller for feed the wire 2
10	Upper roller for feed the wire 3	11	Upper roller for feed the wire 4	12	Frequency controller
13	Emergency stop switch	14	Main switch		

3. The back view of the machine

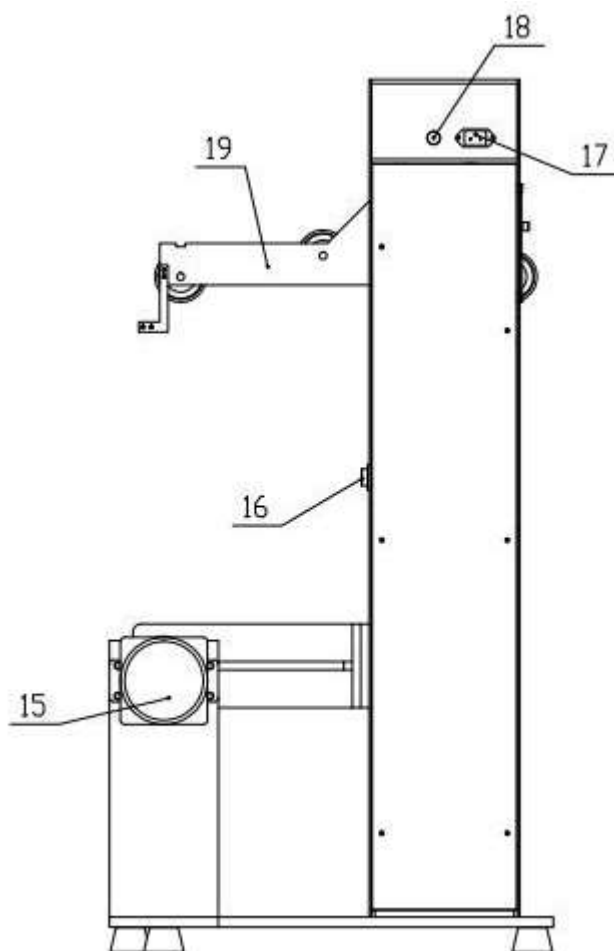

Pic.4 The back view of the machine

4. Component details of back view

15	Motor	16	The Plug connects to the motor	17	AC220V 3 phase power plugs
18	Base for keeping the safety tube	19	Support board of wire feed plate	20	

3. Operating instruction

1、Pull out *the button for adjusting the pressure(10)*, at the same time roll it in the counter clockwise for half circle, then push it back to the former position. Pull out the wire to go through *upper roller for feed the wire(7)*, *objective wire feed roller(9)*, *upper roller for feed the wire 1(11)* and *lower roller for feed the wire(4)*, then go back to *upper roller for feed the wire 2(12)*. Then pull out *the button for adjusting the pressure(10)* again and roll it in the clockwise to adjust the pressure, adjust the 1/4 circle for single line, and 1/2 circle for more.

2、Insert the power plug into the socket of AC220V \pm 10%V which behind the machine. Then turn on the *main switch(14)* and the *emergency stop switch(13)*.

3、When *lower roller for feed the wire(4)* rises up, the lower check sensor will get the signal and output it in the same time. The signal will make the motor the run and start to feed the wire. When lower roller for feed the wire(4) come near to upper roller for feed the wire 1 (11) and upper roller for feed the wire 2 (12), the upper check sensor will get the signal and output it in the same time. The signal will make the motor stop. *Plate for feed the roller(5)* control the inertia of the plate, and it also can control other devices to stop at the same time.

4、Method of winding



Pic.5 Sketch map of winding

4. wiring diagram

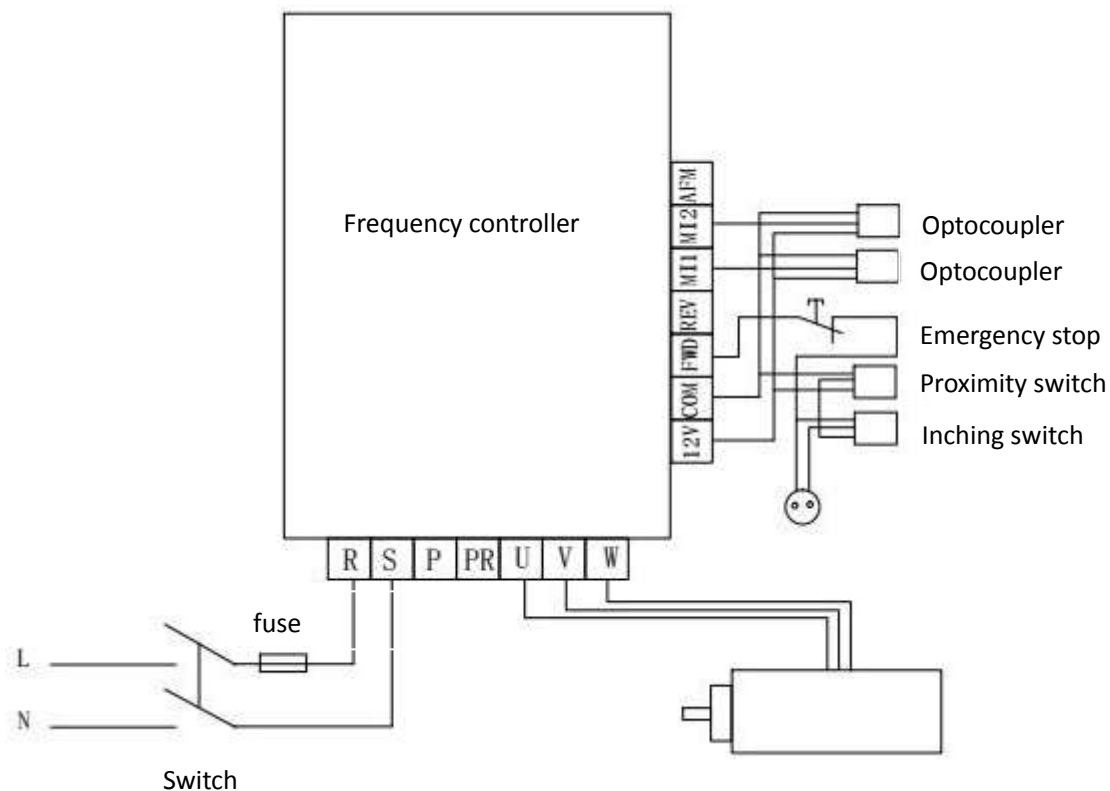

5. Frequency converter setting

D176	=1 Restore factory settings
D1	=0 Parameter locked, =1 Parameters can be modified
D32	=1 Control mode is external start
D10	=15 Brake start frequency
D11	=0.4 Acceleration time
D12	=0.4 Deceleration time
D0	=20 First segment speed
D122	=24 Second segment speed
D124	=28 Third segment speed
D123	=32 Fourth segment speed
D45	=25 DC braking position
D47	=0.3 Brake time /s

服务热线：0573-82331888 82330999

www.junquan.com

浙江君权自动化设备有限公司

地址：中国浙江省乐清市海屿工业区

电话/Tel: 0086-577-62900000 62901111 82199999

传真/Fax: 0086-577-62902918 62902199

E-mail: junquan@wz.zj.cn

嘉兴君权自动化设备有限公司

地址：浙江省嘉兴市经济开发区塘汇路 586 号

电话/Tel: 0086-573-82331888 82330999

传真/Fax: 0086-573-82301199

华东一区

地址：浙江省嘉兴市经济开发区塘汇路 586 号

电话 (Tel) : 0573-82331888 82330999

华东二区

地址：浙江省乐清市海屿工业区

电话 (Tel) : 0577-62900000 62901111

华北大区

地址：郑州市金水区优胜北路上都国际大厦 B 座 1518 室

电话 (Tel) : 0371-56608999 63953399

华南大区

地址：深圳市宝安区西乡大道 782 号万骏汇商务公寓 607 室

电话 (Tel) : 0755-89638399 89637269

西南大区

地址：重庆市渝北区大竹林康庄美地 C 区 17 栋 6/2

电话 (Tel) : 023-67305528 67305527